

THE GENERAL—TG1 SPECIFICATION

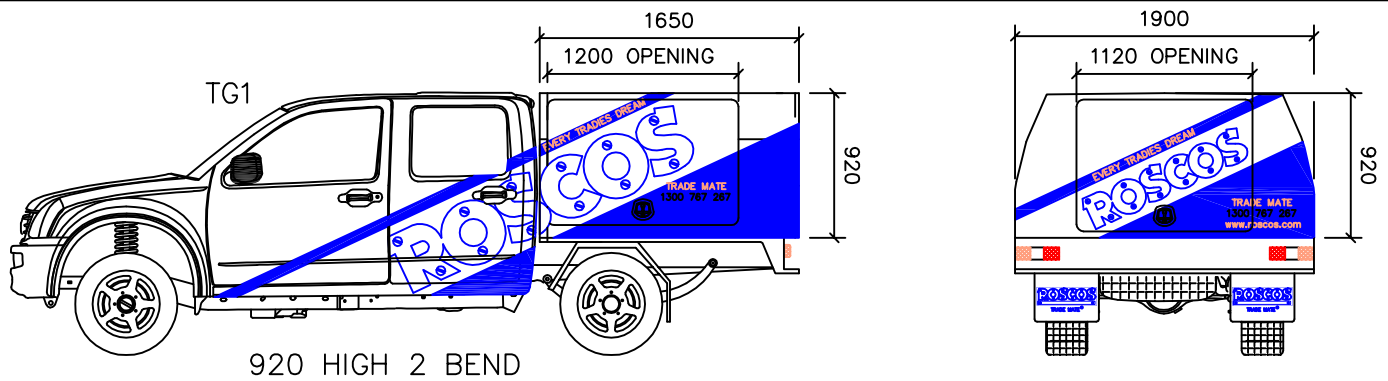

DESCRIPTION: The General is a three-door body with two side doors and a rear door. Including an interior light, side door safety switches and is colour coded to match the cab (Metallic extra). This Trade Mate is bolted directly to the chassis.

SUITABLE FOR DUAL CAB VEHICLES

Make & Model

- Ford Ranger Crew cab chassis (dual cab)
- Nissan Navara Dual cab chassis
- Holden Rodeo crew cab chassis (dual cab)
- Toyota Hilux Dual cab chassis
- Holden Crewman (1900mm wide)
- Mazda Bravo Dual cab chassis
- Mitsubishi Triton Double cab chassis (dual cab)
- 100 Series Toyota Landcruiser cut downs
- Nissan Patrol cut downs

***Please note:** Locations for toolboxes & water tanks are determined by cab chassis specifications & area availability.

OPTIONS:

- *Underslung water tank (rear only)
- *Underslung toolbox (rear only)
- *Remote central locking (if fitted to cab)
- *Front and rear windows
- *Side door window
- *Security mesh
- *Slide out or vertical vices (100mm or 125mm)
- *Bi-fold door (door opening reduced by 20mm)
- *Lock mat flooring
- *Slide out shovel tray (130mm)
- *Slide out shovel tray safety switch
- *Adjustable Gas bottle restraints (up to 300mm)
- Including ratchet strap & floor vents
- *Roof or roof rack mounted Swivel work lamp
- *Roof or roof rack Revolving amber beacon
- *Brake, tail, reverse & indicator assembly mounted to roof rack or back panel (pair)
- *Roof or roof rack mounted brake/tail lights (pair)
- *Roof or roof rack front & rear facing indicators (pairs)
- *Roof racks
- *Side Steps (rear only)
- *Shelving
- *Spring upgrades

***All measurements listed are approximate and are only to be used as a guide. Management reserves the right to alter measurements without notice.**